

WZ16 Integrated IR Bullet Camera

www.boschsecurity.com



BOSCH
Invented for life



Advantage Line

The WZ16 provides reliable day and night surveillance in a compact, water resistant design that integrates 18 infrared LEDs.

Incorporating a SuperHAD 1/3 in CCD, the camera delivers 520 TVL color imaging during the day and 20 m (66 ft) of active-infrared night vision. The mechanical filter technology minimizes IR bleed and prevents focus shift.

For indoor and outdoor environments, the WZ16 is a quick and easy Plug-and-Play solution for 24/7 day and night surveillance.

Features

- ▶ Outstanding low light performance
- ▶ Surveillance at zero lux
- ▶ Flexible viewing angle
- ▶ Discreet outdoor operation
- ▶ Quick installation

2 | WZ16 Integrated IR Bullet Camera

Technical specifications

Video	
Signal Processing	Digital signal processing (DSP)
CCD Camera	1/3 in SuperHAD CCD
Filter	IR-Cut, lens mounted
Resolution	High resolution 520 TVL
Effective Pixels (H x V)	PAL: 752 x 582, NTSC: 768 x 494
Night-Time Sensitivity	0 lux (infrared on)
Electronics Iris	1/50 to 1/100,000 s (PAL), 1/60 to 1/100,000 s (NTSC)
Output Signal	1 VPP composite video, 75 ohm
S/N Ratio	Greater than 45 dB
Gamma	0.45
Lens	Varifocal 3.8 to 9.5 mm, DC auto-iris
LEDs	Infrared array, photocell-controlled
Wavelength	850 nm
Number of LEDs	18
Electrical	
Voltage	12 VDC or 24 VAC
Power Draw	7 W Max.
Power Supply	Not included
Mechanical	
Construction	Robust aluminum extrusion
Finish	Anodized silver
Sunshield	Included
Bracket	Pan-tilt bracket included
Weight	0.56 kg (1.2 lb)
Dimensions	Ø 60 x 145 (L) mm (2.4 x 5.7 in)
Environmental	
Operation Temperature Range	-30 °C to +55 °C (-22 °F to +131 °F)
Environment	IP67 compliant
Certifications and approvals	
Region	Certification
Europe	CE
Standards	
	ANSI C63.4: 1992
	FCC Part 15 subpart B, Class B
	UL 60065, 7th Edition, 2007-12-11
	CAN/CSA-C22.2 No. 60065-03, 1st Edition, 2006-04 + A1:2006
	EN55022:1998 / A1:2000 / A2:2003
	EN50130-4:1995 / A1:1998 / A2:2003
	LVD 2006/95/EC
	EN60065:2002 + A1:2006 + A11:2008
	IP67, IEC 60529 (2001), IEC 60529 (2001)

Installation/configuration notes

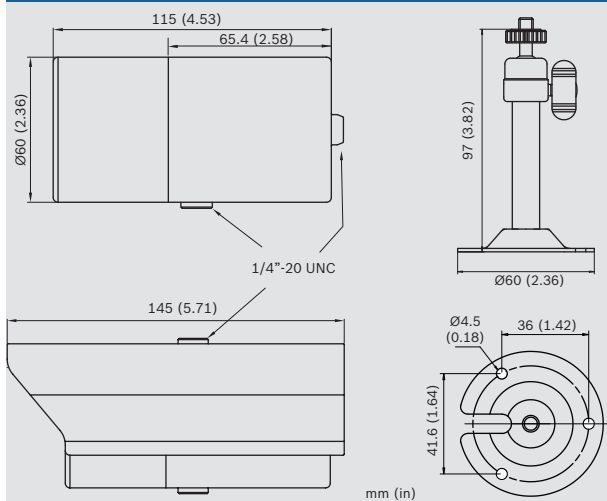

Ordering information

VTI-216V04-2 WZ16 Integrated IR Bullet Camera, NTSC	VTI-216V04-2
VTI-216V04-1 WZ16 Integrated IR Bullet Camera, PAL	VTI-216V04-1
UPA-1220-60 Power Supply	UPA-1220-60
UPA-1220-50 Power Supply	UPA-1220-50

Represented by:

Americas:

Bosch Security Systems, Inc.
130 Perinton Parkway
Fairport, New York, 14450, USA
Phone: +1 800 289 0096
Fax: +1 585 223 9180
security.sales@us.bosch.com
www.boschsecurity.us

Europe, Middle East, Africa:

Bosch Security Systems B.V.
P.O. Box 80002
5617 BA Eindhoven, The Netherlands
Phone: +31 40 2577 284
Fax: +31 40 2577 330
emea.securitysystems@bosch.com
www.boschsecurity.com

Asia-Pacific:

Robert Bosch (SEA) Pte Ltd, Security Systems
11 Bishan Street 21
Singapore 573943
Phone: +65 6571 2808
Fax: +65 6571 2699
apr.securitysystems@bosch.com
www.boschsecurity.asia

China:

Bosch (Shanghai) Security Systems Ltd.
201 Building, No. 333 Fuquan Road
North IBP
Changning District, Shanghai
200335 China
Phone +86 21 22181111
Fax: +86 21 22182398
www.boschsecurity.com.cn

America Latina:

Robert Bosch Ltda Security Systems Division
Via Anhanguera, Km 98
CEP 13065-900
Campinas, Sao Paulo, Brazil
Phone: +55 19 2103 2860
Fax: +55 19 2103 2862
al.securitysystems@bosch.com
www.boschsecurity.com